

**SEBHYDRO**

9 bis rue des bonnets  
58260 LA MACHINE  
[sebhydro@sebhydro.com](mailto:sebhydro@sebhydro.com)  
[www.sebhydro.com](http://www.sebhydro.com)  
06 50 19 44 25



## Hydraulics, Training, Expertise 2022

**SEBHYDRO**

**Qualiopi**  
processus certifié  
RÉPUBLIQUE FRANÇAISE

**Tailor-made on-site training adapted to your company with practical part on your machines.**

Face-to-face or webcam training.

Satisfaction rate: 95%

Performance rate: 85%

### FUNDING:

Many devices can allow you to finance the costs related to the training of your employees.

For any information or registration request you can contact by email or complete the "Information / registration request" form

# HYDRAULIC SAFETY

Hydraulic training adapted to your machines. (4 people)

Training alternating 70% theoretical and 30% practical.

For anyone with a disability, please contact me.

**Duration:** 1 day (7H) face-to-face or (7H by webcam per 2H module). Price : Contact us

## WHO SHOULD ATTEND?

### Intern profile

1. Anyone needing to work on hydraulic drives.

### Prerequisite

2. General mechanical knowledge.

## EDUCATIONAL GOALS

- ✓ Know the hydraulic risks.
- ✓ To be able to intervene on an installation by applying the safety instructions.

## PEDAGOGICAL PROGRESSION

### 1. CAUSES OF ACCIDENT

Risks (pressure, hoses, driving loads...)  
Penetration of fluid into the human body.

### 2. RISK ANALYSIS

Identification of risks (Purge, filter change, flexible change, adjustment, repair...)  
Protection system (anti whip, anti-jet).  
Personal protective equipment

### 3. CONSIGNMENT

Identification, consignment, verification, control, discharge.

### 4. HOSES

Service life, storage, inspection.

### 5. PRACTICAL APPLICATION

Analysis of the intervention from the diagram.  
Listing of risks.  
Identification of components.  
Intervention on machine.

### 6. EVALUATION

End of internship questionnaire.



# BASIC HYDRAULICS

Hydraulic training adapted to your machines. (4 people)

Training alternating 70% theoretical and 30% practical.

For anyone with a disability, please contact me.

**Duration:** 4 days (28H) face-to-face or (24H by webcam per 2H module). Price : Contact us

## WHO SHOULD ATTEND?

### Intern profile

Person responsible for the operation and maintenance of hydraulic drives.

### Prerequisite

General mechanical knowledge.

## EDUCATIONAL GOALS

- ✓ Know the basics.
- ✓ Understand how the components work.
- ✓ Provide the basics for schematic reading.

## PEDAGOGICAL PROGRESSION

### 1. THE BASICS

Relationship between pressure/force and flow/speed.  
Pressure drops, flow resistance...

### 2. OPERATION OF THE COMPONENTS

Pumps and motors (gears, pallets, pistons).  
Pressure: limiters, reducers, anti-shock valves, counterbalance valves...  
Flow: limiters, flow regulators, flow dividers...  
Standard and proportional directional valves.  
Logic valves.  
Symbolization.

### 3. SAFETY

Risks (pressure, hoses, driving loads...)  
Penetration of fluid into the human body.

### 4. PRACTICE

Reading machine diagrams.  
Identification of components on the machine.  
Pressure taking and interpretation.

### 5. EVALUATION

End of internship questionnaire.

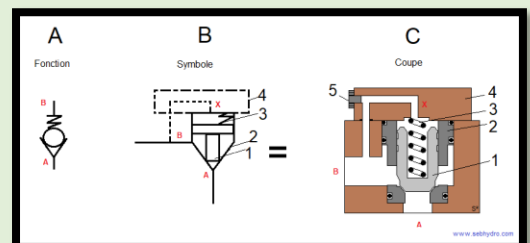

# HYDRAULIC SYSTEM WITH REGULATION

Hydraulic training adapted to your machines. (4 people)

Training alternating 50% theoretical and 50% practical.

For anyone with a disability, please contact me.

**Duration:** 4 days (28H) face-to-face or (24H by webcam per 2H module). Price : Contact us

## WHO SHOULD ATTEND?

### Intern profile

Person responsible for the operation and maintenance of hydraulic drives.

### Prerequisite

General mechanical knowledge.

Mastery of basic knowledge.

## EDUCATIONAL GOALS

- ✓ Adjustment of hydraulic components.
- ✓ Know how to take and interpret measurements.
- ✓ Interpret a hydraulic diagram.

## PEDAGOGICAL PROGRESSION

### 1. OPERATION OF THE COMPONENTS

Open circuit / loop circuit (hydrostatic)

Variable displacement pumps. (Constant pressure regulation, power regulation, Load Sensing).

Pressure: limiters, reducers, anti-shock valves, counterbalance valves...

Flow: limiters, flow regulators, flow dividers...

Proportional directional valves Load Sensing & 6/3.

Symbolization.

### 2. SETTING

Valve adjustment procedure.

Adjustment of pumps.

### 3. SAFETY

Risks (pressure, hoses, driving loads...)

Penetration of fluid into the human body.

### 4. PRACTICE

Failure breakdown study on machine diagrams.

Component identification on machine.

Pressure taking and interpretation.

### 5. EVALUATION

End of internship questionnaire.

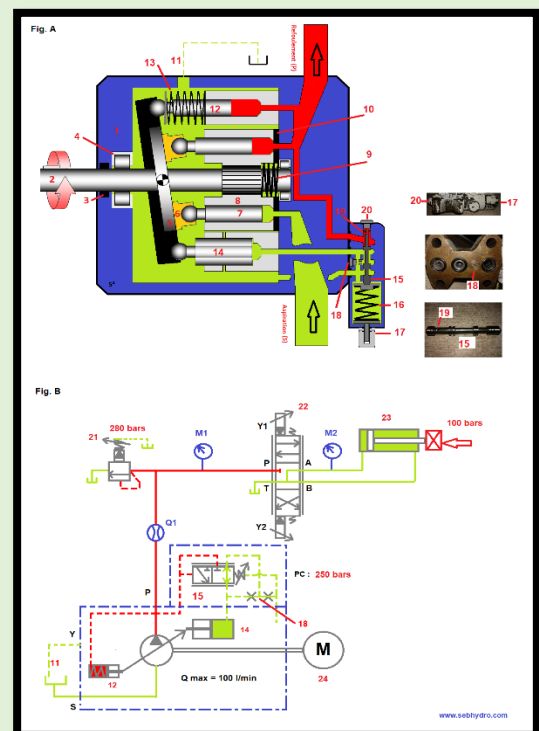

# HYDRAULICS TROUBLESHOOTING

Hydraulic training adapted to your machines. (4 people)

Training alternating 50% theoretical and 50% practical.

For anyone with a disability, please contact me.

**Duration:** 4 days (28H) face-to-face or (24H by webcam per 2H module). Price : Contact us

## WHO SHOULD ATTEND?

### Intern profile

Person responsible for the operation and maintenance of hydraulic drives.

### Prerequisite

General mechanical knowledge.

Mastery of basic knowledge.

## EDUCATIONAL GOALS

- ✓ Establish a commissioning procedure.
- ✓ Preventive maintenance.
- ✓ Know how to troubleshoot using the diagram.

## PEDAGOGICAL PROGRESSION

### 1. OPERATION OF THE COMPONENTS

Pumps and motors (gears, pallets, pistons).

Variable displacement pumps. (Constant pressure regulation, power regulation, Load Sensing).

Pressure valves / Flow valves – Standard directional valves and cylinders.

Open circuit / Hydrostatic circuit.

Oil / Filtration / Pollution.

Symbolization.

### 2. SETTING

Valve control procedure.

Pump control.

### 3. SAFETY

Risks (pressure, hoses, driving loads...)

Penetration of fluid into the human body.

### 4. PRACTICE

Failure breakdown study on machine diagrams.

Component identification on machine.

Pressure taking and interpretation.

### 5. EVALUATION

End of internship questionnaire.

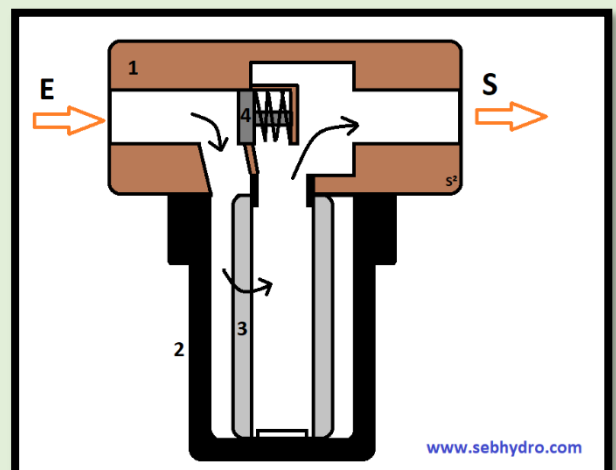

# BASIC ON-BOARD ELECTRICITY

Electric training adapted to your machines. (4 people)

Training alternating 50% theoretical and 50% practical.

For anyone with a disability, please contact me.

**Duration:** 4 days (28H) face-to-face or (24H by webcam per 2H module). Price : Contact us

## WHO SHOULD ATTEND?

### Intern profile

Person responsible for the operation and maintenance of the electrical systems of machines. (TP, VL, PL)

### Prerequisite

General mechanical knowledge.

## EDUCATIONAL GOALS

- ✓ Know the basics.
- ✓ Understand how components work.
- ✓ Provide the basics for reading the diagram to optimize troubleshooting.

## PEDAGOGICAL PROGRESSION

### 1. THE BASICS

Ohm's law (Current / Voltage / Resistance)  
Calculation, sizing of cables and fuses.

### 2. OPERATION / TEST OF COMPONENTS

Operation and use of the multimeter.  
30A relay, diode, resistor, potentiometer, flasher unit, transistor, alternator, starter ...  
Search for ground fault and connection.  
Construction and creation of electrical circuits on test boards.  
Introduction to multiplexing.  
Symbolization.

### 3. PRACTICE

Reading machine diagrams.  
Starting circuit test on machines.  
Wiring on test box.

### 4. EVALUATION

End of internship questionnaire.

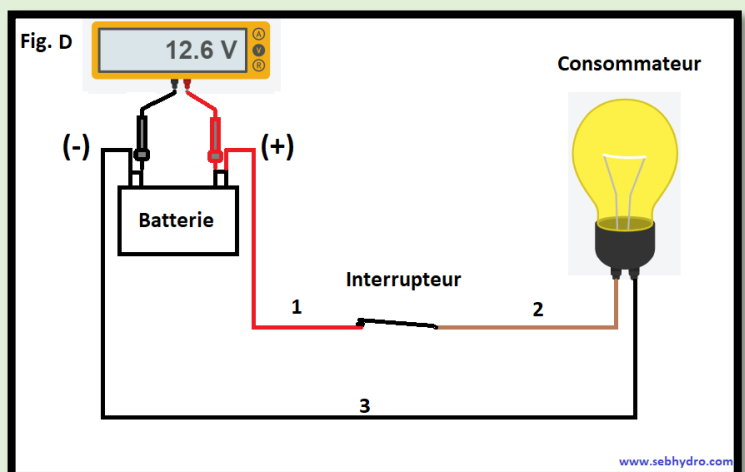



### **Expertise, safety audit.**

Limit the risks of your machine park: (hoses, accumulators, risks related to the pressure ...)

- 1- General condition of the machine
- 2- Condition of all hoses (aging, anti-whip, jet breeze sheaths ...)
- 3- Condition of fittings, flanges and accumulators ...
- 4- Check the presence of the counter balance valves, parachute valves, pilot poppet valves on the cylinders subjected to the driving loads ...

### **Expertise, filtration audit.**

Observation on the filtration set up, oil analysis, advice ...

- 1- State of the machine environment
- 2- State of leaks ...
- 3- State of the filtration, state of the filters in place ...
- 4- Oil analysis ...

### **Expertise, maintenance audit.**

Improve hydraulic maintenance, reduce breakdowns, guide investments, advice ...

- 1- General condition of the machine and its environment
- 2- Condition of all hoses (aging, anti-whip, jet breeze sheaths ...)
- 3- Condition of fittings, flanges and accumulators ...
- 4- Check the presence of the counter balance valves, parachute valves, pilot poppet valves on the cylinders subjected to the driving loads ...
- 5- State of leaks ...
- 6- State of the filtration, state of the filters in place ...
- 7- Oil analysis
- 8- Pressure control, adjustments ...
- 9- Control of motor leaks and pumps (drain) ...

### **Hydraulic pump control and adjustment**

A control of the pumps makes it possible to carry out preventive measures, to reduce the failure rate and the costs. An HS pump can pollute the entire hydraulic circuit.

# The Library

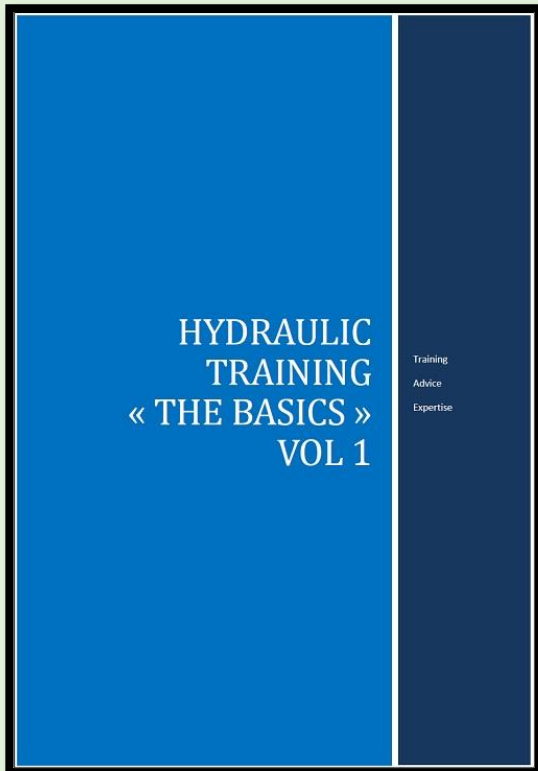

**44.99€ HT**

**True hydraulic training: Simple explanation, understood by all**

**Find in this book 20 courses (118 pages)**

Here are the main topics:

- The basics
- Disassembly and operation of external gear pumps
- Direct operated pressure relief valve
- Pilot operated pressure relief valve
- The flow in a jet: The Bernoulli theorem
- 2-way and 3-way flow regulator operation
- 4/3 directional valve
- How to test the hydraulic cylinders
- Dimension a hydraulic circuit for a 40T press
- Etc...

ISBN 978-2-491341-01-5

<https://www.sebhydro.com/en/store/hydraulic-training-the-basics-vol-1/>



**SEBHYDRO**

9 bis rue des bonnets  
58260 LA MACHINE  
[sebhydro@sebhydro.com](mailto:sebhydro@sebhydro.com)  
[www.sebhydro.com](http://www.sebhydro.com)  
06 50 19 44 25

**Request REGISTRATION / INFORMATION**

Response within 48 hours

**Name:**

**First name:**

**Society:**

**Address:**

**Traineeship:**

**Comment :**